

DELTA PULSE MODULATION

Note: This regulation was previously Tels A 121. Pages 1 and 2, Issue 2, shew the new EMER number and they supersede those pages Issue 1, dated 12 Aug 54. The EMER number on pages 3 to 5 is to be amended to Tels A 021.

INTRODUCTION

1. The pulse code modulation system transmits a code that represents completely the amplitude of the signal; this code is sufficient to reconstitute the signal at the point in question in complete independence of the signal characteristics at previous sampling points. Delta pulse modulation, on the other hand, transmit a code representing the change in amplitude of the signal from one sampling point to the next.
2. At the transmitter an "approximating signal" is generated from a series of small increments of voltage, by adding or subtracting a small increment of voltage of constant amplitude, which can be either positive- or negative-going; the addition or subtraction of these small increments is made at regular intervals, the "digit" rate, in such a way that the approximating signal is made to follow as closely as possible the modulation waveform which is to be transmitted. The decision as to the sign of each increment to be added to the approximating signal is determined by a "comparator" circuit which, at regular intervals, compares the amplitude of the approximating signal after the previous addition (or subtraction), with that of the modulation waveform; if the former is greater then a negative increment is added, and vice-versa. The amplitude of the increment and the "digit" rate are so chosen as to be capable of producing an approximating signal with a fixed incremental rate of change greater than the maximum rate of change that the modulation waveform will present. The decisions made by the comparator circuit at these regular intervals are translated into a binary pulse train (e.g. a mark when a positive increment is added, and a space for a negative increment) which is transmitted to the receiver. At the receiver a similar approximating signal is then built up from locally generated signal increments, the decision as to the sign of successive increments being controlled by the incoming pulse train.
3. In Figure 1 is shewn a part of a modulation waveform (solid line), and superimposed on this is shewn a typical approximating signal (dotted line); an enlarged portion of this diagram is shewn in Figure 2. The arrowed vertical lines at the bottom of the diagrams indicate the instants at which the comparator circuit operates to determine the relative amplitudes of the two waveforms. The positive and negative increments added to the approximating signal take the form of a saw-tooth rise or fall of voltage of substantially constant slope.
4. It will be clear from Figure 1 that the higher the rate at which the comparator circuit operates the greater will be the accuracy with which the approximating signal can follow the modulation waveform, and the less the distortion. In practice it is found that this rate of operation should be between ten and twenty times as great as the highest component frequency in the modulation waveform which it is desired to transmit. For example, speech of good telephone quality, containing component frequencies up to 3000c/s, can be transmitted with the comparator circuit operating at about 40kc/s; by means of various improvements to the basic method this rate can be reduced about 30kc/s. Since the rate at which the comparator circuit operates is also the basic speed at which mark/space pulses must be transmitted between sending the receiving terminals, the requirements of the system as regards band-width of the transmission link are similar to those for pulse code modulation; similarly the advantages of pulse code modulation, as regards immunity from added distortion and noise on long-distance repeatered circuits, also apply.

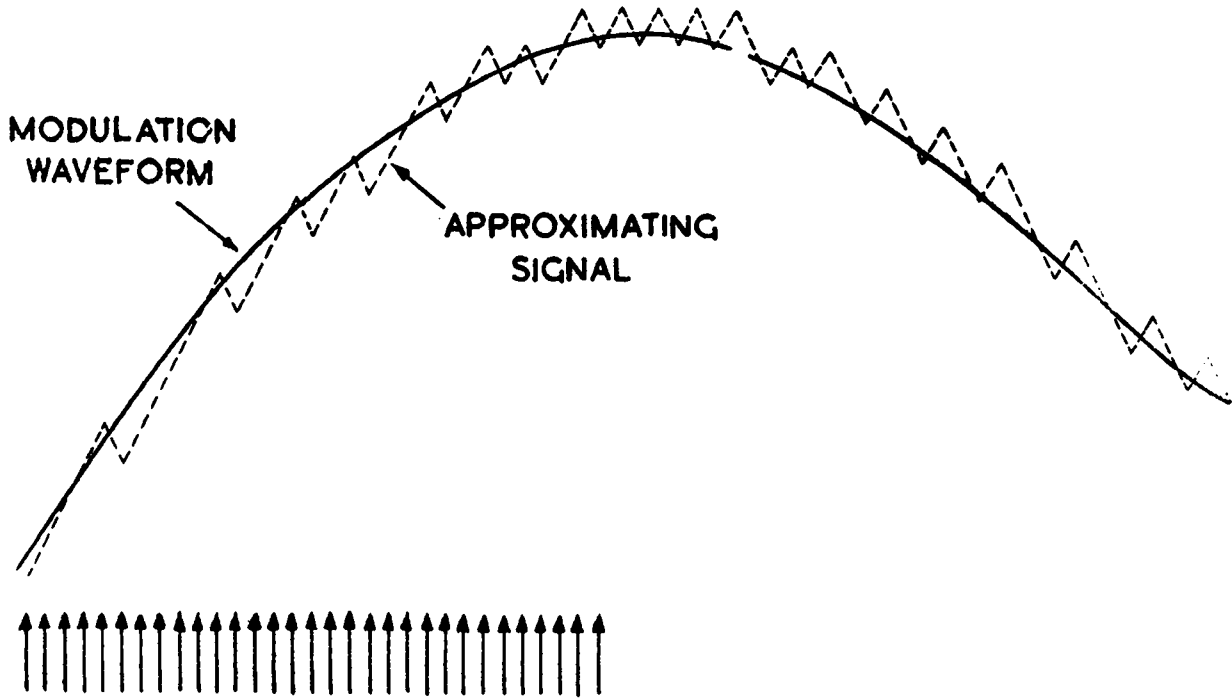

A-021
2-1

Fig. 1

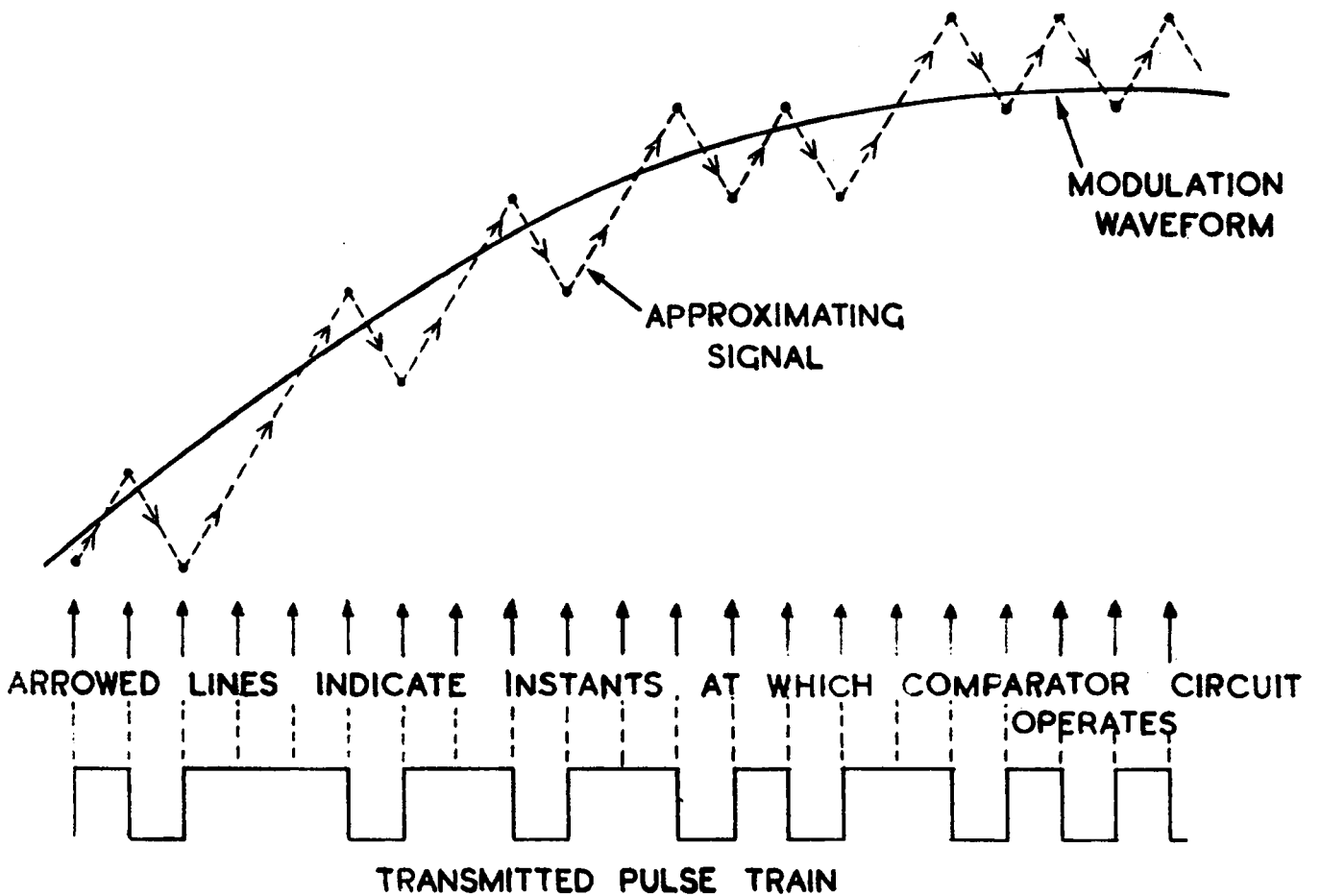

BASIC SYSTEM

Transmitter

5. In Figure 3 is shown a block diagram of a simple delta pulse modulator. The comparator circuit has a composite input consisting of the modulation waveform, the approximating signal, and a source of short-duration timing pulses, these three individual inputs being added in series as shown.

6. The approximating signal is generated as the output from a simple resistance-capacity integrating network; when such a network is fed with a train of mark/space pulses, and provided that the time-constant (i.e. the product of R and C) of the network is large compared with the duration of each pulse, the output will be a portion of an exponential rise or fall in voltage as the input is mark or space respectively.

7. The comparator circuit is arranged so that at each timing pulse a mark or space output is generated according to whether the approximating signal is of lesser or greater amplitude respectively than the instantaneous value of the modulation waveform. This mark/space output, as well as being the signal to be transmitted to the distant receiver, is also used as the input signal to the integrating network.

Receiver (Fig. 4)

8. At the receiver the train of mark/space pulses is first regenerated, and then applied directly to an integrating network identical with that used in the modulator; the output from this network will then be a replica of the approximating signal in the modulator, and therefore a close approximation of the original modulation waveform. The output is then passed through a low-pass filter to "smooth out" the incremental changes in amplitude.

DELTA PULSE MODULATION CHARACTERISTICS

9. The most significant feature of delta pulse modulation, as compared with pulse code modulation, is that the pulse train, which is transmitted between the modulator and the demodulator, requires no form of group synchronisation; the only synchronising action required in the system is to recover the basic digit frequency at the receiver, in order to operate regenerating circuits, and on links of adequate bandwidth and good signal/noise ratio such regeneration may not always be required. The method does therefore offer a very simple way of obtaining all the advantages of transmitting speech in the form of a train of mark/space pulses, but without the added complication of the synchronisation required by normal pulse code modulation.

COMPARISON OF THE TWO PULSE MODULATION SYSTEMS

10. In general, the apparatus required for a delta pulse modulation system is simpler than that for an equivalent pulse code modulation system; against this is the fact that the delta modulation method requires a somewhat higher basic pulse rate, and therefore a greater bandwidth in the transmission link, than does a pulse code modulation system giving the same quality of reproduction.

11. The overload characteristic of a delta modulation system also differs from that of pulse code modulation. In the latter the overload limit occurs when the modulating waveform becomes large enough to reach the extreme quantising levels, and

is independent of frequency. For the delta modulation, the limiting factor is the maximum rate of rise or fall of the approximating signal, this in turn being determined by the time-constant of the integrating network; this maximum rate occurs when the output from the integrating network consists of a succession of all-positive or all-negative saw-tooth increments.

12. The nett result of this limitation is that the overload level (i.e. the maximum amplitude which can be transmitted) is inversely proportional to the modulating frequency.

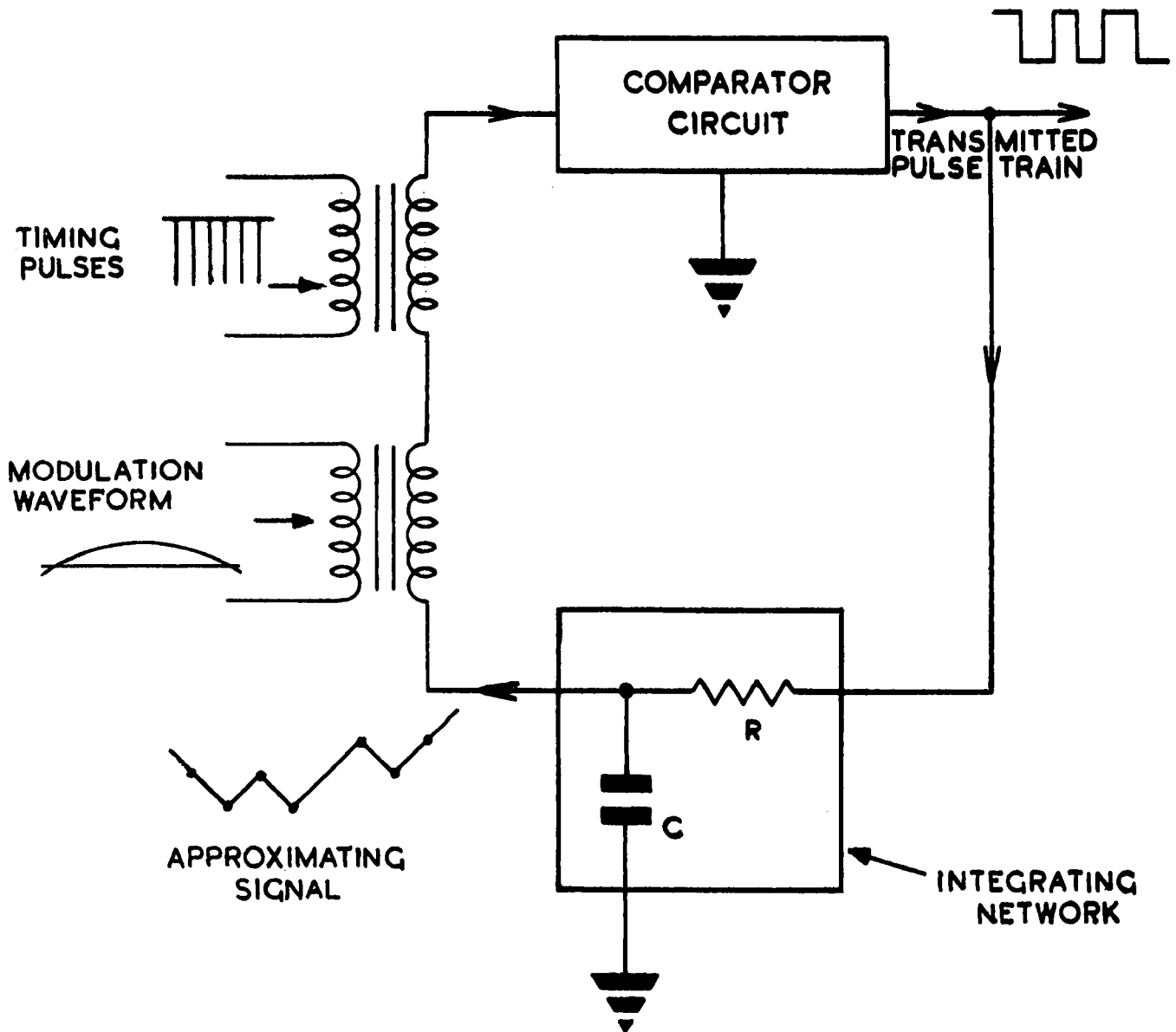
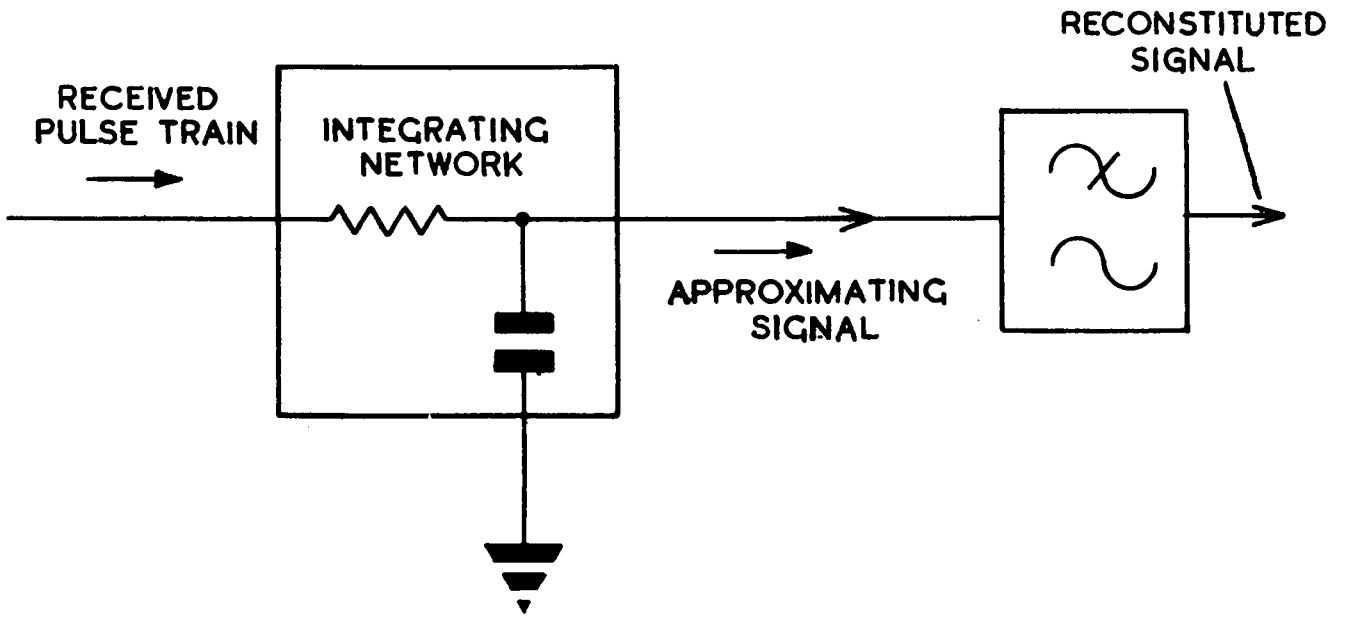

Fig. 3



A-121
1-4

Fig. 4

END